

SR-DC2000 Installation Instructions

1 Getting Started

The SR-DC2000 is an integrated Input / Output board that provides connections for up to four supervised F/2F readers, together with the associated door furniture (door lock, exit-request switch, door monitor contact, alarm bypass output and Aux output). It also provides 10 general-purpose Monitor Point inputs and 8 general-purpose Auxiliary Relay outputs.

Please note:

- The SR-DC2000 always requires a SR-DB2000 Database Unit to be installed for operation. It cannot be used alone, or with any other Database Unit.
- The SR-DC2000 has built in pull up resistors, External pull up resistors are not required.
- End-of-line resistors are required only for 4-state supervision of REX and door status inputs.
- Connections with door furniture must be done through the reader or an external interface.

Note: For additional information regarding the installation, configuration and proper use of this product please refer to:

- SR-Node Migration/Installation manual, 9600-0632
- SR-DBU/DB2000 Installation Instructions, 9600-0625

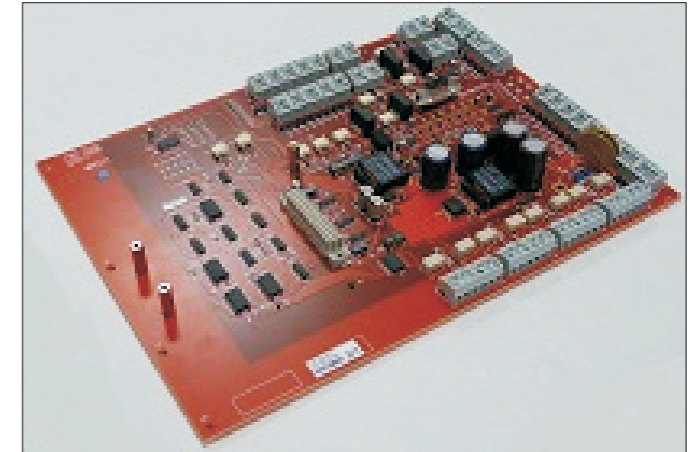

Package Contents

The package should be delivered free from visible damage and include the following contents:

- SR-DC2000 Reader Board
 - 20 x 1K Ω , 0.25W resistors
- 9600-0647 SR-DC2000 Installation Leaflet (this document)

If any of the items are missing or damaged please contact the supplier immediately.

Please observe ESD precautions when handling or storing the SR-DC2000 to prevent any damage.



2 Connection and Wiring Details

Cable Selection

It is recommended that 20AWG shielded cable is used to connect any reader to the SR-DC2000.

Note before starting installation:

1. Consult local AHJ (Authority Having Jurisdiction) when installing access control readers and locking mechanisms to any portal in an egress path.
2. The use of Fail Closed / secure configuration shall be determined by the local building codes and the local AHJ.
3. Wiring methods will be in accordance with NEC (National Electric Code) ANSI/NFPA 70.

Connecting readers

1. Install the reader as specified with the manufacturers instructions.
2. All cable between the reader and the SR-DC2000 must be brought through an appropriate knockout in the Enclosure
3. Tie all shields together and secure to the grounding block at the bottom of the enclosure, or to earth stud closest to the knockout used in the cabinet enclosure.
4. Twisted Pairing of cables is required.

Specifications

Input voltage: 18V a.c / 24V d.c.
Input current: 3A a.c. 2A d.c all relays energised, excluding readers.
Relay rating 2A, 30VDC or 0.50A, 120VAC maximum per output point.
Operating temperature: 35 to 122°F (2 to 50°C)
Operating humidity: 5% to 95%, non-condensing at 90°F (32°C).
Cabling: Multi conductor, 20AWG shielded pairs.

SR-DC2000 Input Addressing

Input	Physical Addressing		Symmetry Addressing	
	Board Address	Input Number	DC	Input Number
1-8	1	1-8	1	1-8
9-10	1	9-10	2	1-2

Typical wiring of J16 Micro Powered (Fallback) Port

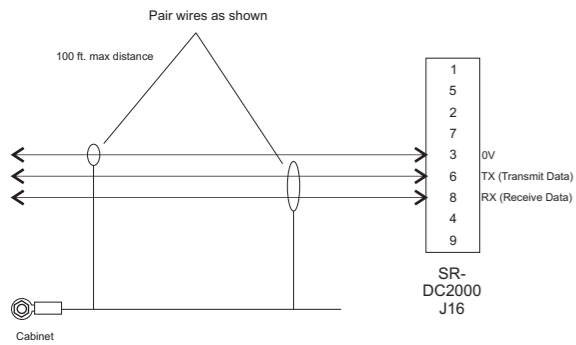

Typical wiring of J16 Micro Powered (Host) Port

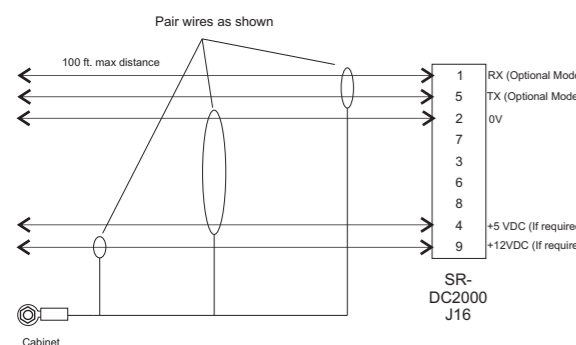

SR-DC2000 DIP switch settings for reader technology and format

Reader technology and format	SW5-1	SW5-2	SW5-3	SW5-4
Supervised F/2F	ON	OFF	ON	OFF

Wiring the SR-DC2000 Digital Inputs (J2 & J3)

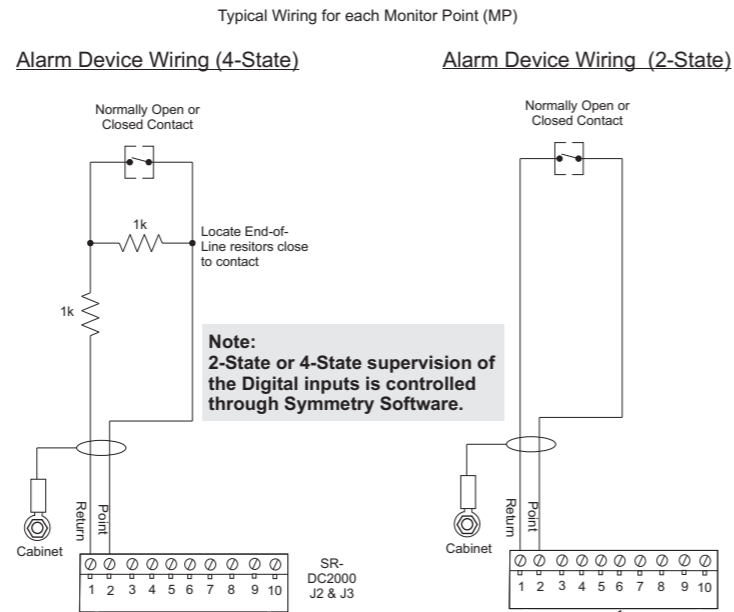

Wiring SR-DC2000 to Supervised F/2F Reader Devices

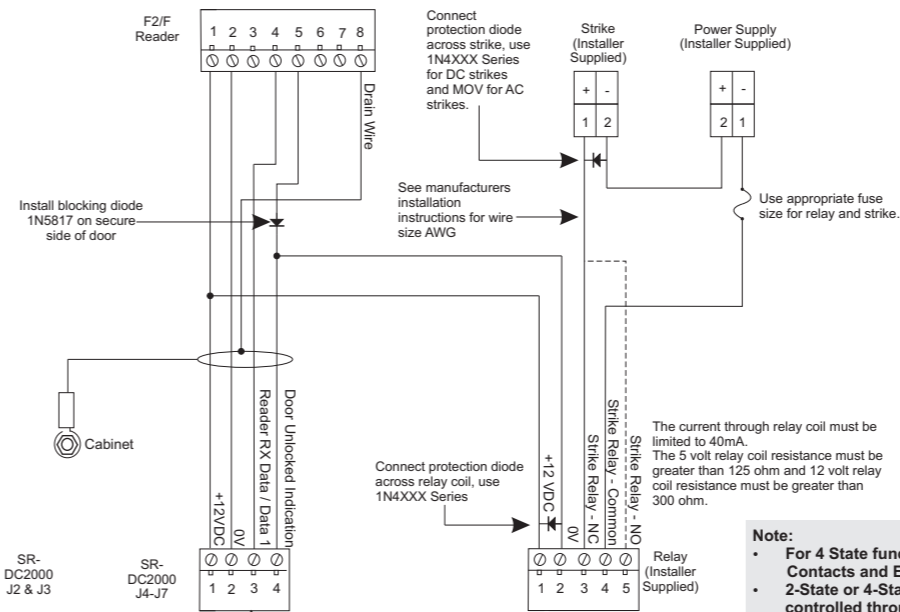

SR-DC2000 Reader Addressing

Input	Physical Addressing		Symmetry Addressing	
	Reader Number	Board Address	DC	Reader Number
1-2	1	1-2	1	1-2
3-4	1	3-4	2	1-2

Typical wiring of J8 & J9 (RS-232 Primary / Secondary and Fallback Ports) Connectors

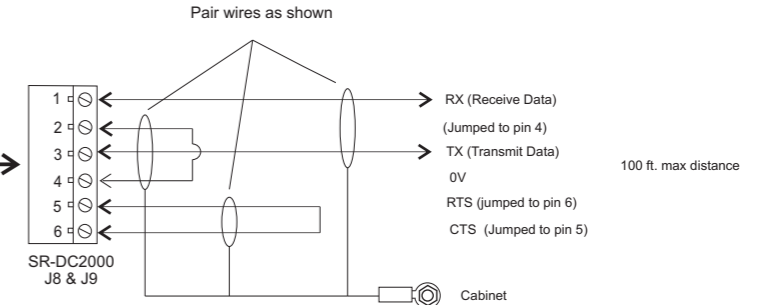

Typical wiring of J10 (RS-422 Micro Port) Connector

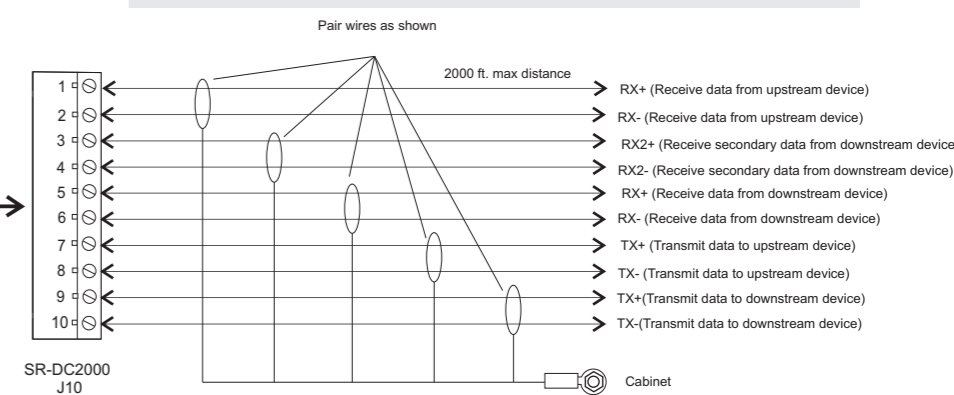

Typical Wiring of J11(Power and Tamper Connector)

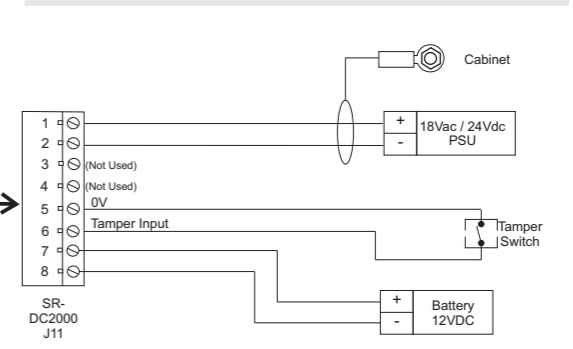

SR-DC2000 Output Addressing

Input	Physical Addressing		Symmetry Addressing	
	Board Address	Output Number	DC	Output Number
1-8	1	1-8	1	1-8

Wiring the SR-DC2000 Auxiliary Outputs (J12 - J15)

